

Providing Quality Engineering For Our Water Resources Since 2002

Client

Milwaukee County, Milwaukee, WI
 Architecture, Engineering and Environmental Services Division
 (SSE was a subconsultant to EarthTech)
 Contact: Steve Keith, Division Managing Engineer
 (414) 278-3922

Project

Lake Park Raingardens and Bradford Beach Stormwater Project

Overview/Description

Stormwater Solutions Engineering, LLC contracted as a subconsultant to Earthtech with Milwaukee County to design raingardens at Lake Park (N. Wahl Avenue at E. Bellevue) and create Operations and Maintenance Guidance for Park Staff for all Bradford Beach Filtration devices and Lake Park raingardens.

Concerns/Challenges

- Bradford Beach had experienced beach closings due to poor water quality
- E-Coli bacteria was present in wet and dry weather storm sewer outfall testing
- Lake Park was a popular dog-walking area that was thought to be contributing to the water quality issues at Bradford Beach
- Milwaukee County desired a low-maintenance water quality treatment alternative and guidance for County staff on maintenance that would be required

Actions Addressing Challenges

- SSE designed three raingardens for Lake Park, collecting water from all areas of the park near Wahl and Bellevue and treating it through infiltration and plant root uptake
- Use of Wisconsin native landscaping within the raingardens allows for low-maintenance attractive, landscaping
- Operation and Maintenance Guidance was prepared for the infiltration devices (designed by others) and for the raingardens (designed by SSE). A laminated one-page, two-sided document was provided for County staff to be kept in vehicles for easy access.



Pollutants caused contaminated beach sands downstream

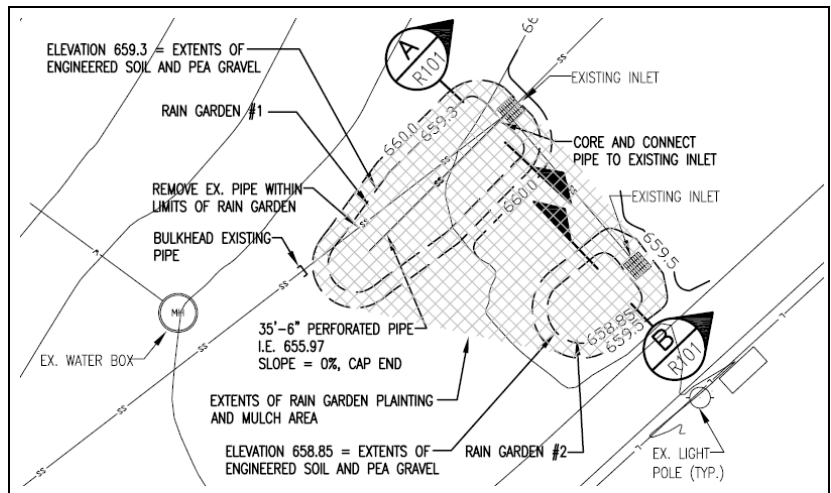

Design of Raingardens for Lake Park to Collect and Treat Runoff

"The rain gardens in Lake Park that your firm designed look and work great!"

(Milwaukee County Environmental Engineer)



Aerial Photo of Raingarden Post-Construction



Post-Construction Rain Garden with Informational Signage



Stormwater Solutions Engineering, LLC

100 East Sumner Street | Hartford, WI 53027

Phone: (262)673-9697 | Fax: (262)397-8426

Web: www.stormwater-solutions-engineering.com